

CM-23152-000

SHT 1.1

NOTE:

 A POSITIVE GOING VOLTAGE AT TERMINAL 2  
RELATIVE TO TERMINAL 1 CAUSES AN INCREASE  
IN PRESSURE AT THE SOUND OUTLETS.

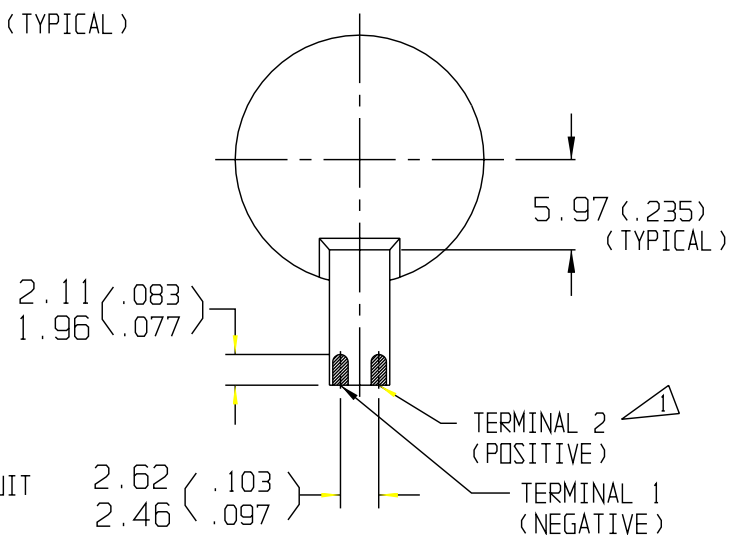
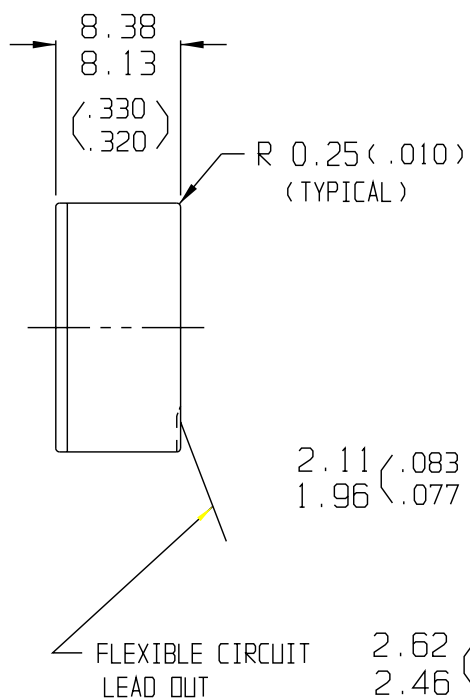
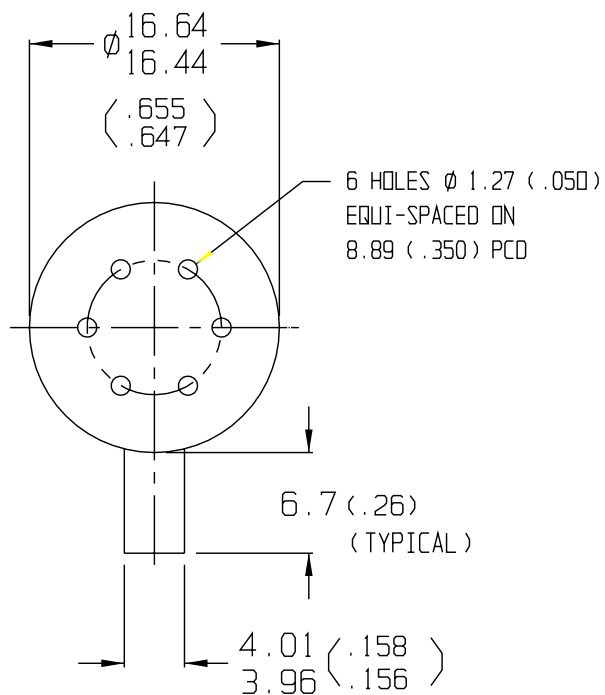

NOMINAL WEIGHT  
1.5 GRAMS

DIMENSIONS IN MILLIMETERS (INCHES)

ISSUE

B

KNOWLES ELECTRONICS

KNOWLES ELECTRONICS, INC., ITASCA, ILLINOIS U.S.A.

KNOWLES ELECTRONICS, CO., BURGESS HILL, SUSSEX, ENGLAND

SCALE: 2:1

DO NOT SCALE DRAWING

I

TITLE: EARPIECE  
OUTLINE DRAWING

CM-23152-000  
SHT 1.1

DR. BY DATE

AB 1-4-06

CK. BY DATE

GJP 1-8-06

APP. BY DATE

GJP 1-8-06

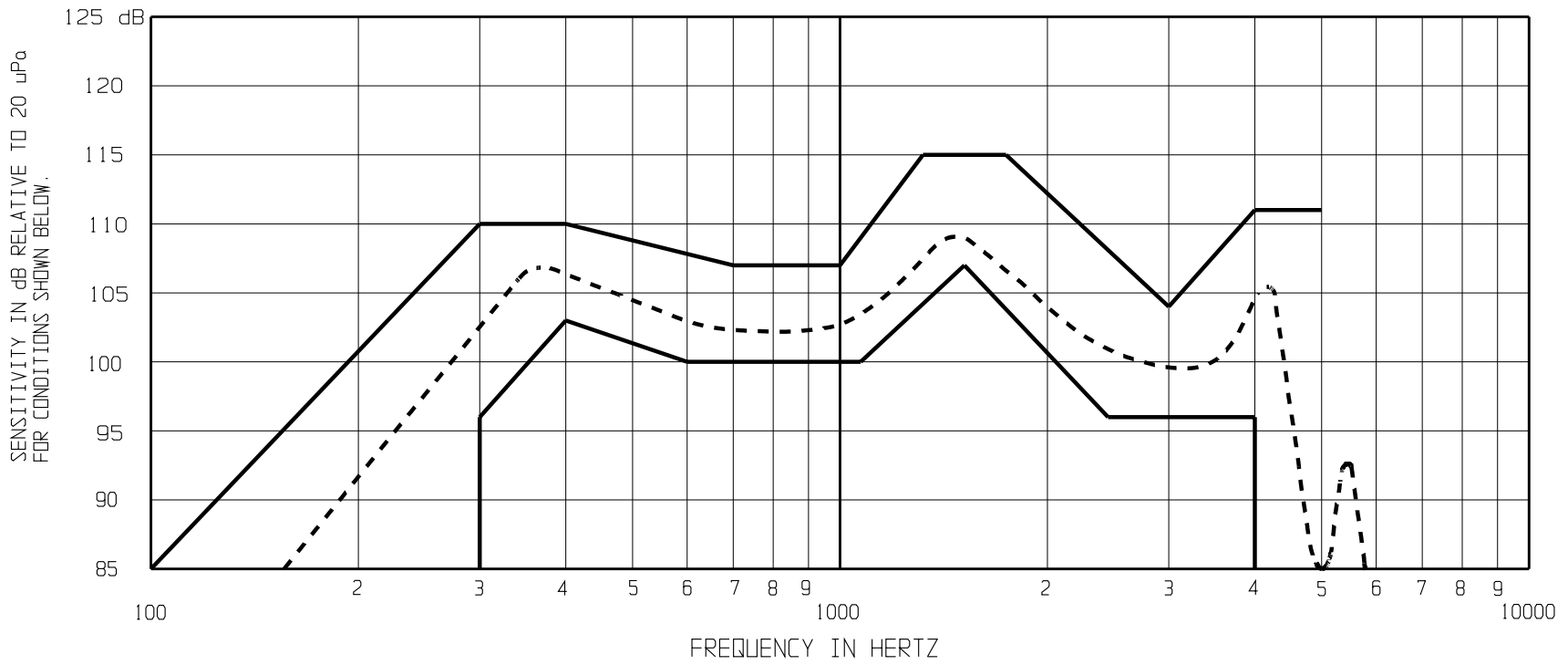

NOTES:

1. MEASUREMENTS MADE WITH UNIT UNDER TEST, SEALED TO AN IEC 318 COUPLER ( BRUEL & KJAER PART No. 4153 ).
2. ELECTRICAL SIGNAL ( SEE # 6 BELOW )

SENSITIVITY			SENSITIVITY Contd )		
FREQUENCY	MIN.	MAX.	FREQUENCY	MIN.	MAX.
100	---	85.0	1400	---	115.0
300	96.0	110.0	1600	107.0	---
400	103.0	110.0	1800	---	115.0
600	100.0	---	2500	96.0	---
700	---	107.0	3000	---	104.0
1000	---	107.0	4000	96.0	111.0
1100	100.0	---	5000	---	111.0

4. THERE WILL BE NO BUZZ OR RATTLE WHEN DRIVEN AT MAXIMUM DRIVE ( SEE # 6 BELOW ) & SWEPT FROM 300 Hz TO 4 KHz.
5. RESPONSE AND DISTORTION MEASUREMENTS MADE USING ELECTRICAL CONDITIONS SHOWN BELOW.
6. INDIVIDUAL SPECIFICATIONS.

STD DRIVE		DISTORTION		1 kHz IMP.(±15%)	D.C. RES @ 20°C (±10%)	MAX DRIVE	
VAC RMS	RS OHMS	MAX. %	FREQ Hz			VAC RMS	RS OHMS
0.20	300	2	300	150	69	1.0	300

7. TEST CONDITIONS.

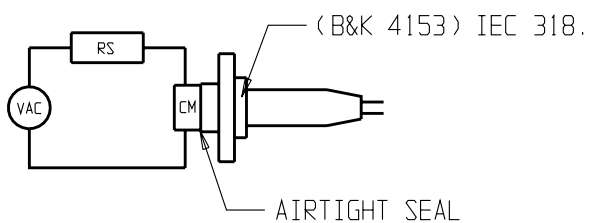

ISSUE  
B

KNOWLES ELECTRONICS

KNOWLES ELECTRONICS, INC., ITASCA, ILLINOIS U.S.A.

When test limits are used to establish incoming inspection acceptance/rejection criteria, correlation of test equipment with Knowles is also required for elimination of equipment and test method variations.

DR. BY	DATE
AB	1-4-06
CK. BY	DATE
GJP	1-8-06
APP. BY	DATE
GJP	1-8-06

TITLE: **EARPIECE**  
PERFORMANCE SPECIFICATION

**CM-23152-000**  
SHT 2.1